

DETAIL K

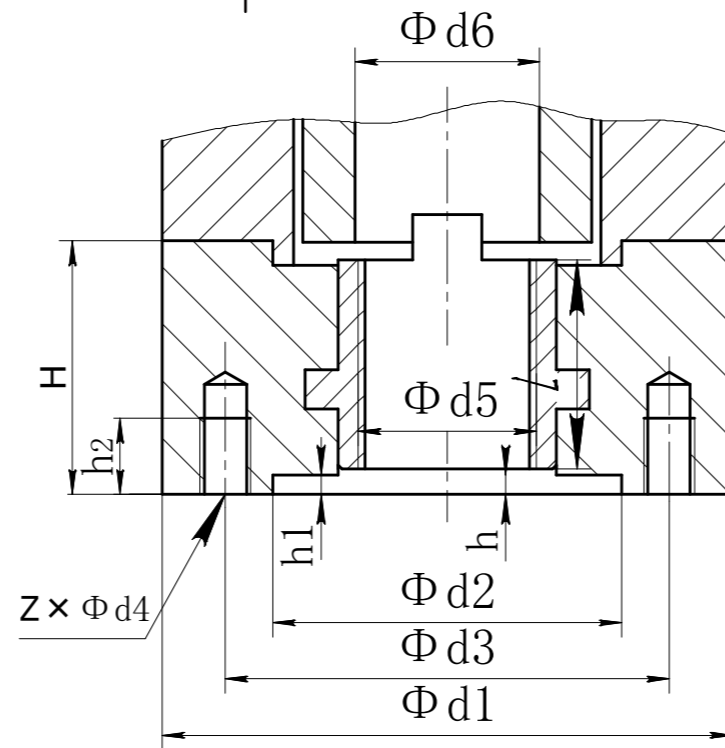

Code	Zahlenwert
kN	160
$\phi d1$	$\phi 175$
$\phi d2$	$\phi 100$
$\phi d3$	$\phi 140$
$\phi d4$	M16
$\phi d5 \text{ max}$	$\phi 58$
$\phi d6$	$\phi 60$
h	2
h1	4.5
h2	25
H	70
L	64
Z	4

Alle Maße in mm
All dimensions in mm

Für alle übrigen Maße der Stellantriebe/Getriebe siehe Maßblatt neuester Ausgabe
For all other dimensions of actuators/gear boxes refer to latest issue of dimension sheet

DIMENSIONS

M.50/02.06

SM(R)50-SC02-F14-A

	Datum	Name
Bearb.	2018.09.18	uffner
Gepr.	2018.09.18	Gerbig

SCHWARZ®

SCHWARZ ACTUATOR GMBH
WWW.SCHWARZ-TECH.COM